

# TYPE 400

# BRONZE BALL VALVE

Screwed body cap, Blowout-proof Stem,  
Double O-ring stem seals  
Threaded ends to BS21 or solder joint ends

*TL, CTL* W.O.G. non-shock 2.76 MPa (400 psi), W.O.G. 150°C 0.69 MPa (100 psi),  
*TLT* W.O.G. non-shock 2.76 MPa (400 psi), W.O.G. 80°C 1.96 MPa (286 psi)

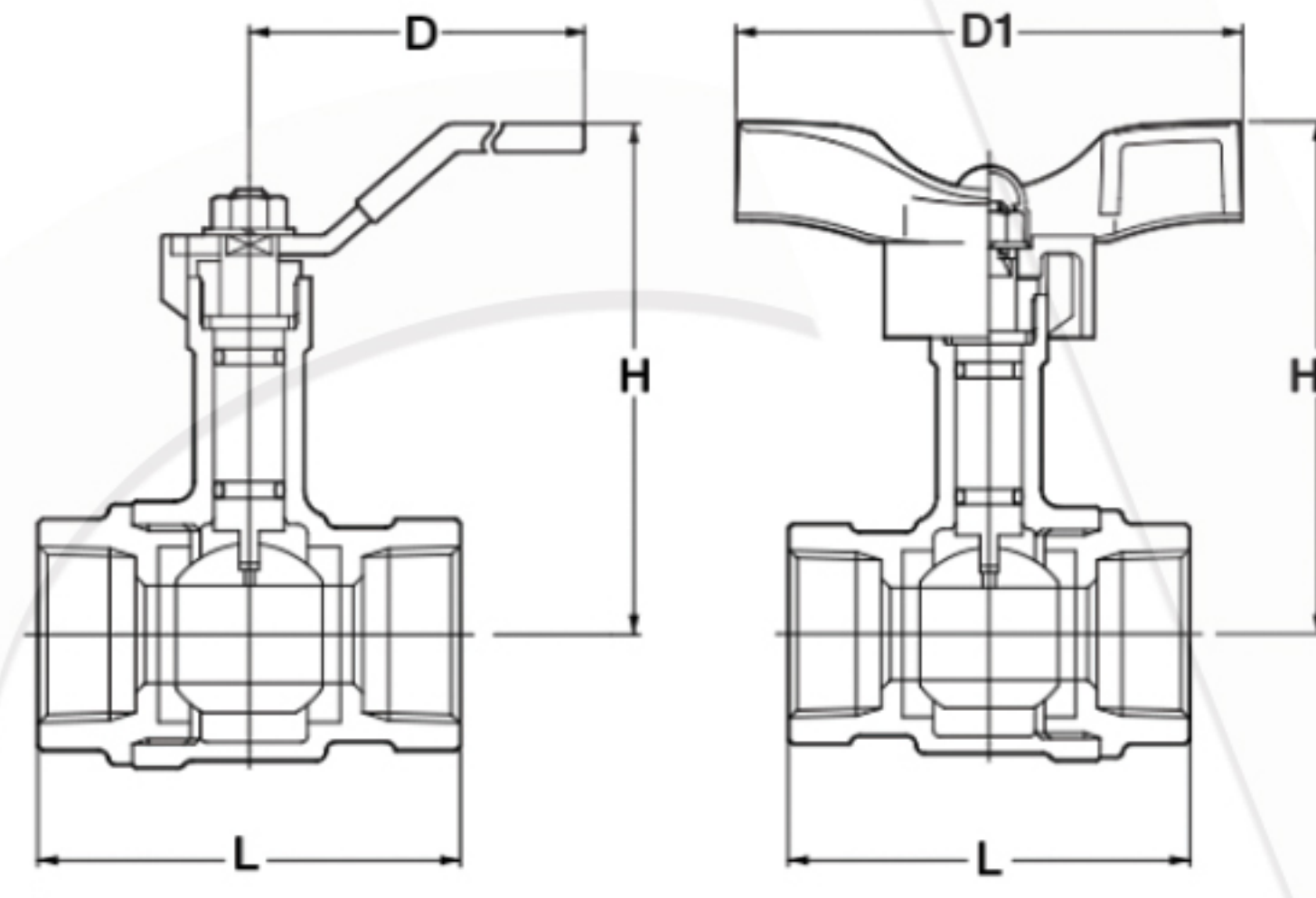

### Materials

Parts	Material
Body	Bronze
Body cap	Bronze
Stem	Dezincification Resistant Brass
Ball	Stainless Steel (Type 304)
Ball seat	PTFE
O-ring	FKM



Solder joint end valves should not be used in service where the temperature of line fluid is higher than the softening point of solder.

### Dimensions

Nominal Size	inch	1/2	3/4	1	1 1/4	1 1/2	2	mm
	mm	15	20	25	32	40	50	
L		56	65	78	86	96	109	
L1 Solder		58	73	88	99	114	135	
H		75	79	83	98	102	109	
H1		79	83	90	105	109	124	
D		80	80	110	110	110	140	
D1		82	82	94	94	94	120	

**Fig. TL**

- Threaded end to BS21